

CA111205

MODEL 1146C

146 x 90 x 68

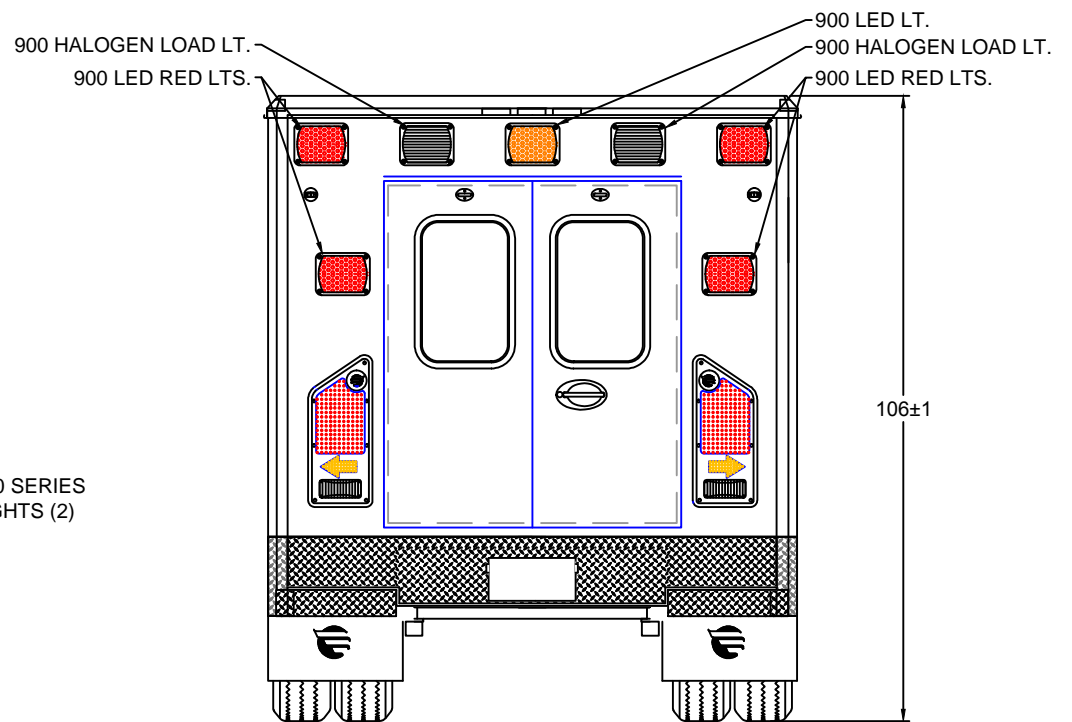
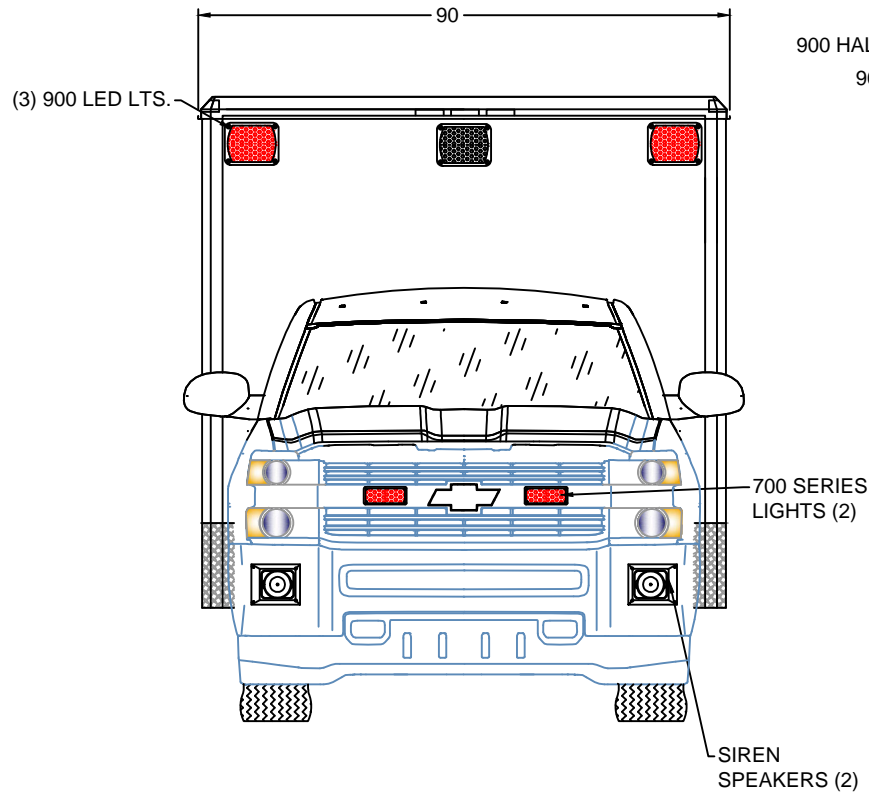

EXTERIOR COMPARTMENT DIMENSIONS IN INCHES

| INTERIOR DIMENSIONS | | | | PASS THRU | | INTERIOR DIMENSIONS | | | | JAMB OPENING | |
|---------------------|--------|-------|-------|-----------|-------|---------------------|--------|-------|-------|--------------|-------|
| COMPT. | HEIGHT | WIDTH | DEPTH | HEIGHT | WIDTH | COMPT. | HEIGHT | WIDTH | DEPTH | HEIGHT | WIDTH |
| | | | | | | | | | | | |
| | | | | | | | | | | | |
| | | | | | | | | | | | |



TYPE 1 CHEVY 2018
FRONT / REAR
EXTERIOR VIEWS

BE ADVISED THAT THESE ARE PRELIMINARY LAYOUTS INTENDED TO ILLUSTRATE DESIGN INTENT AND DIMENSIONS ARE FOR REFERENCE ONLY PRIOR TO FINAL ENGINEERING

| | | |
|--------|----------|--------------|
| DATE: | 04/17/18 | SCALE |
| DWN BY | SG | DWG NO 1 / 9 |

49" AISLE

CA111205

MODEL 1146C

146 x 90 x 68

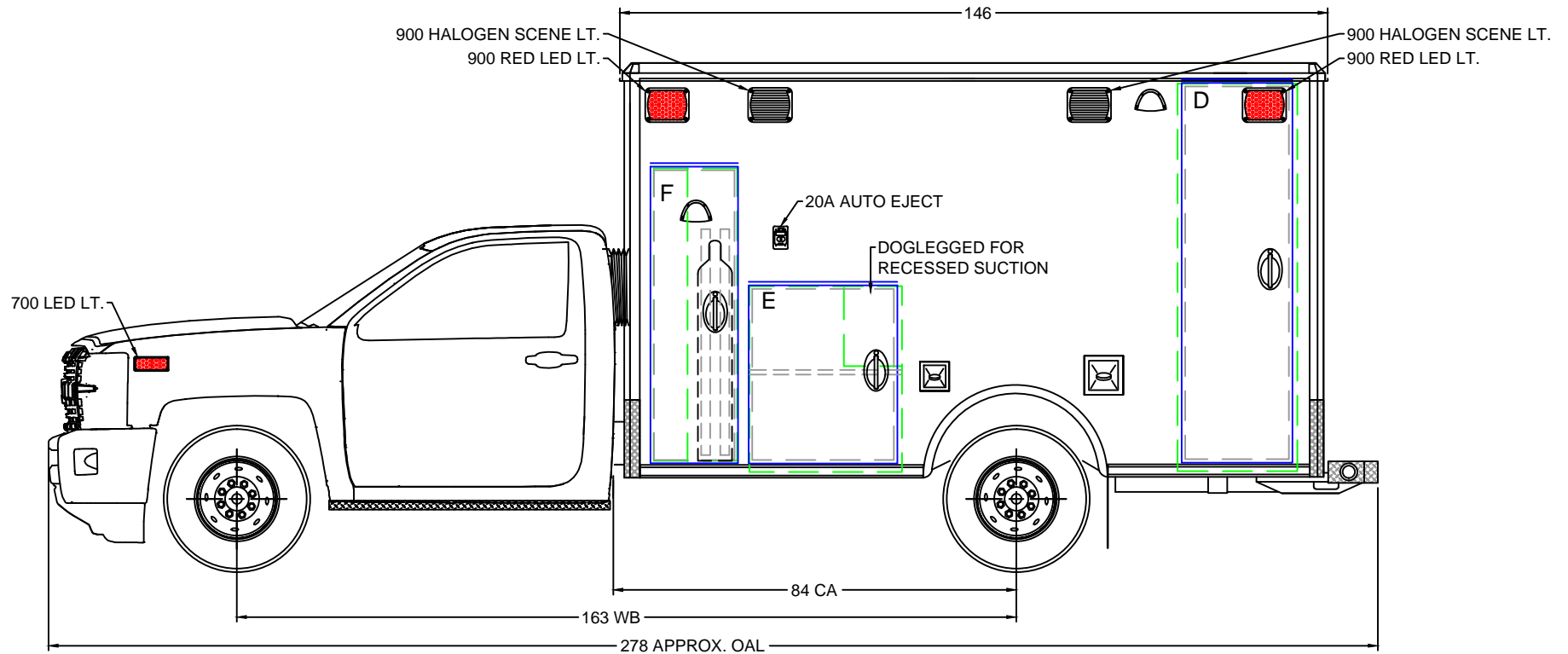

BE ADVISED THAT THESE ARE PRELIMINARY LAYOUTS INTENDED TO ILLUSTRATE DESIGN INTENT AND DIMENSIONS ARE FOR REFERENCE ONLY PRIOR TO FINAL ENGINEERING

| EXTERIOR COMPARTMENT DIMENSIONS IN INCHES | | | | | | | | | | | |  |
|---|--------|-------|-------|--------------|-------|---------------------|--------|-------|-------|--------------|-------|---|
| INTERIOR DIMENSIONS | | | | JAMB OPENING | | INTERIOR DIMENSIONS | | | | JAMB OPENING | | |
| COMPT. | HEIGHT | WIDTH | DEPTH | HEIGHT | WIDTH | COMPT. | HEIGHT | WIDTH | DEPTH | HEIGHT | WIDTH | |
| D | 81.00 | 25.00 | 8.00 | 77.75 | 21.50 | | | | | | | |
| E | 38.75 | 31.75 | 15.00 | 35.75 | 29.50 | | | | | | | |
| F | 61.00 | 17.50 | 15.00 | 60.50 | 16.75 | | | | | | | |
| 49" AISLE | | | | | | | | | | | | DATE 04/17/18 DRAWN BY SG |
| | | | | | | | | | | | | SCALE DWG NO 2 / 8 |

CA111205

MODEL 1146C

146 x 90 x 68

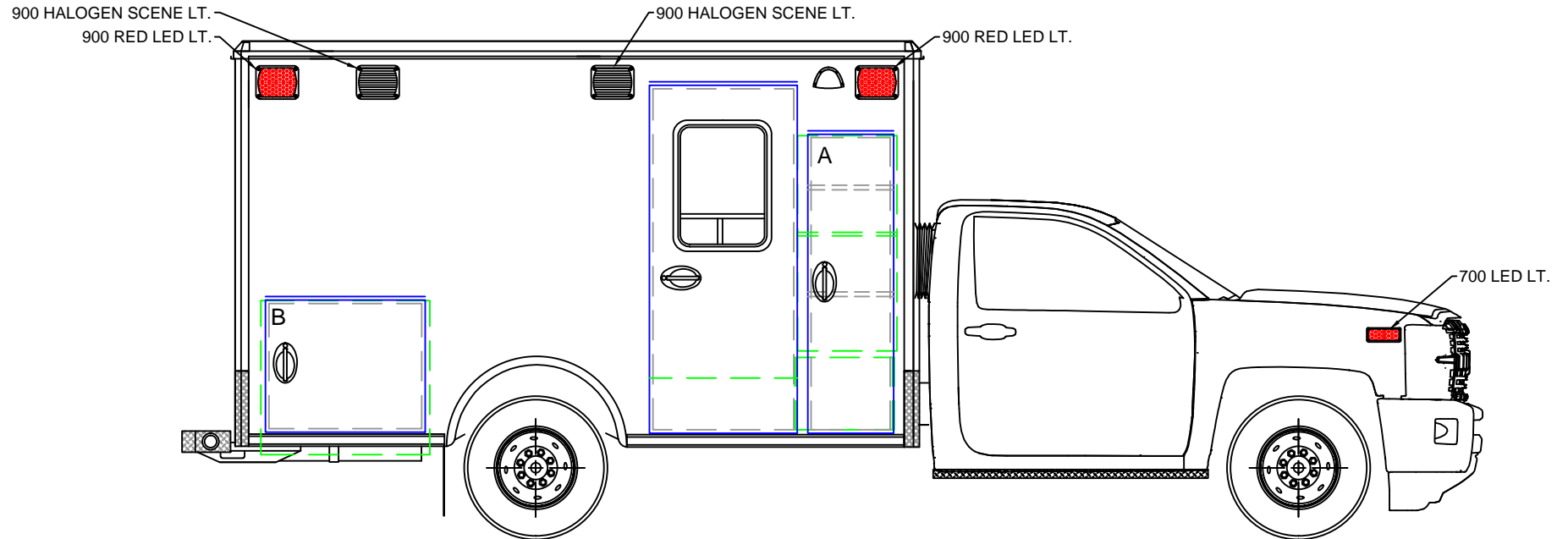

BE ADVISED THAT THESE ARE PRELIMINARY LAYOUTS INTENDED TO ILLUSTRATE DESIGN INTENT AND DIMENSIONS ARE FOR REFERENCE ONLY PRIOR TO FINAL ENGINEERING

| EXTERIOR COMPARTMENT DIMENSIONS IN INCHES | | | | | | | | | | | |  | |
|---|--------|-------|-------|--------------|-------|---------------------|--------|-------|-------|--------------|-------|---|--------|
| INTERIOR DIMENSIONS | | | | JAMB OPENING | | INTERIOR DIMENSIONS | | | | JAMB OPENING | | | |
| COMPT. | HEIGHT | WIDTH | DEPTH | HEIGHT | WIDTH | COMPT. | HEIGHT | WIDTH | DEPTH | HEIGHT | WIDTH | DATE | SCALE |
| A | 45.25 | 21.25 | 32.50 | 61.50 | 16.75 | | | | | | | 04/17/18 | |
| LOWER-A | 15.50 | 19.00 | 18.75 | | | | | | | | | DRAWN BY | DWG NO |
| B | 33.00 | 36.00 | 15.50 | 26.75 | 32.50 | | | | | | | SG | 3 / 9 |
| 49" AISLE | | | | | | | | | | | | | |

TYPE 1 CHEVY 2018
RIGHT EXT. VIEW

CA111205

MODEL 1146C

146 x 90 x 68

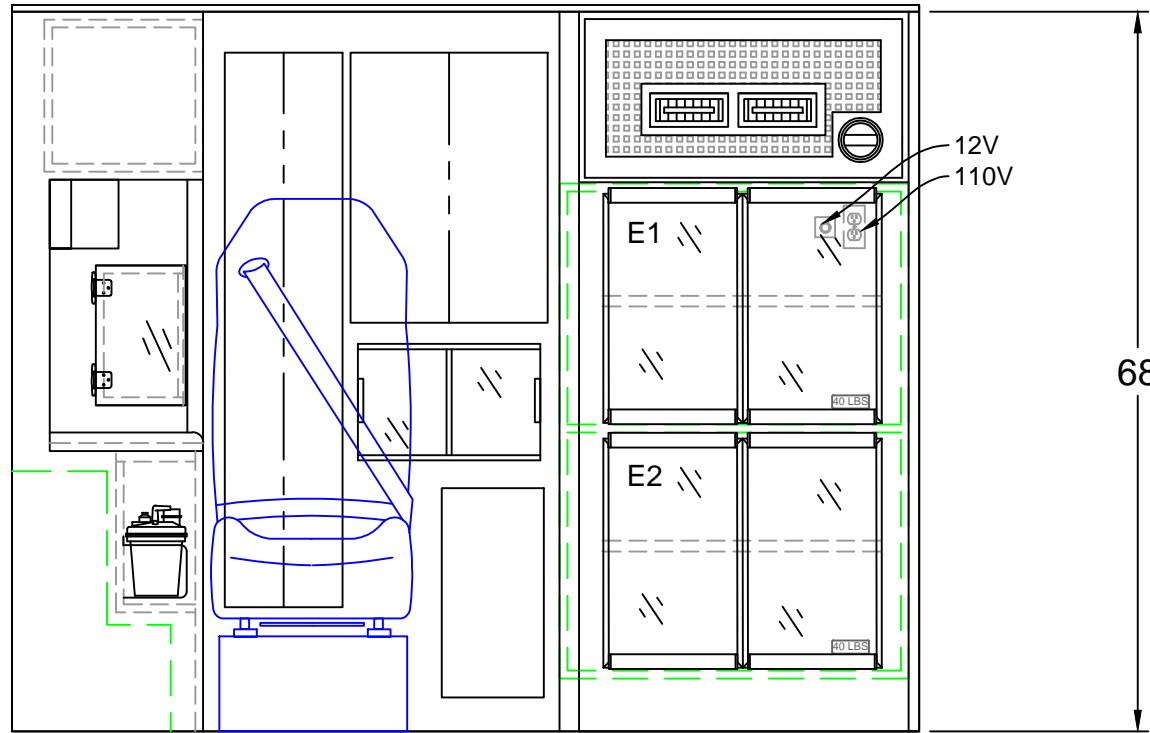

BE ADVISED THAT THESE ARE PRELIMINARY LAYOUTS INTENDED TO ILLUSTRATE DESIGN INTENT AND DIMENSIONS ARE FOR REFERENCE ONLY PRIOR TO FINAL ENGINEERING

| | | | | | | | | | | | |
|--|--|--------|-------|-------|---------|--------|-------|----------|----------|--------|-------|
| <p>CABINET WEIGHT RATINGS: RESTOCKING = 30 LBS. NON-RESTOCKING = 40 LBS.</p> | <p>INTERIOR CABINET DIMENSIONS IN INCHES</p> | | | | | | | | | | |
| | CABINET | HEIGHT | WIDTH | DEPTH | CABINET | HEIGHT | WIDTH | DEPTH | | | |
| | E1 | 22.00 | 32.50 | 21.25 | | | | | | | |
| | E2 | 22.00 | 32.50 | 21.25 | | | | | | | |
| | | | | | | | | | | | |
| | | | | | | | | | | | |
| | | | | | | | | DATE | 04/17/18 | SCALE | |
| | | | | | | | | DRAWN BY | SG | DWG NO | 4 / 9 |

49" AISLE

CA111205

MODEL 1146C

146 x 90 x 68

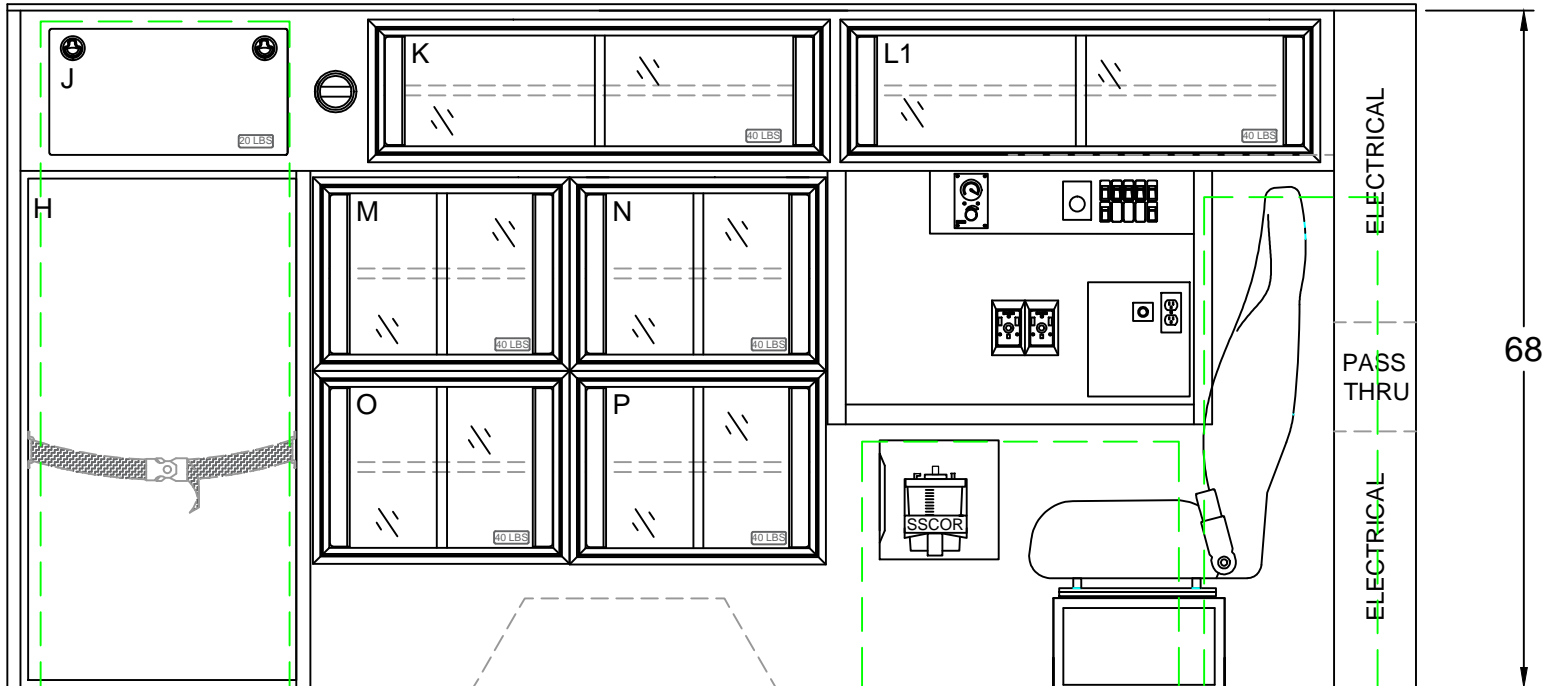

INTERIOR CABINET DIMENSIONS IN INCHES

| CABINET | HEIGHT | WIDTH | DEPTH | | CABINET | HEIGHT | WIDTH | DEPTH | |
|---------|--------|-------|-------|--|---------|--------|-------|-------|--|
| H | 50.50 | 26.75 | 7.75 | | M-N | 18.00 | 24.25 | 16.00 | |
| J | 12.75 | 24.00 | 7.00 | | O-P | 18.00 | 24.25 | 16.00 | |
| K | 12.75 | 45.00 | 16.00 | | | | | | |
| L1 | 12.75 | 46.75 | 13.50 | | | | | | |

49" AISLE

CABINET WEIGHT RATINGS:
 RESTOCKING = 30 LBS.
 NON-RESTOCKING = 40 LBS.

BE ADVISED THAT THESE ARE PRELIMINARY LAYOUTS INTENDED TO ILLUSTRATE DESIGN INTENT AND DIMENSIONS ARE FOR REFERENCE ONLY PRIOR TO FINAL ENGINEERING



TYPE 1 CHEVY 2018

LEFT INTERIOR

DATE: 04/17/18

SCALE

DWN BY: SG

DWG NO: 5 / 9

CA111205

MODEL 1146C

146 x 90 x 68

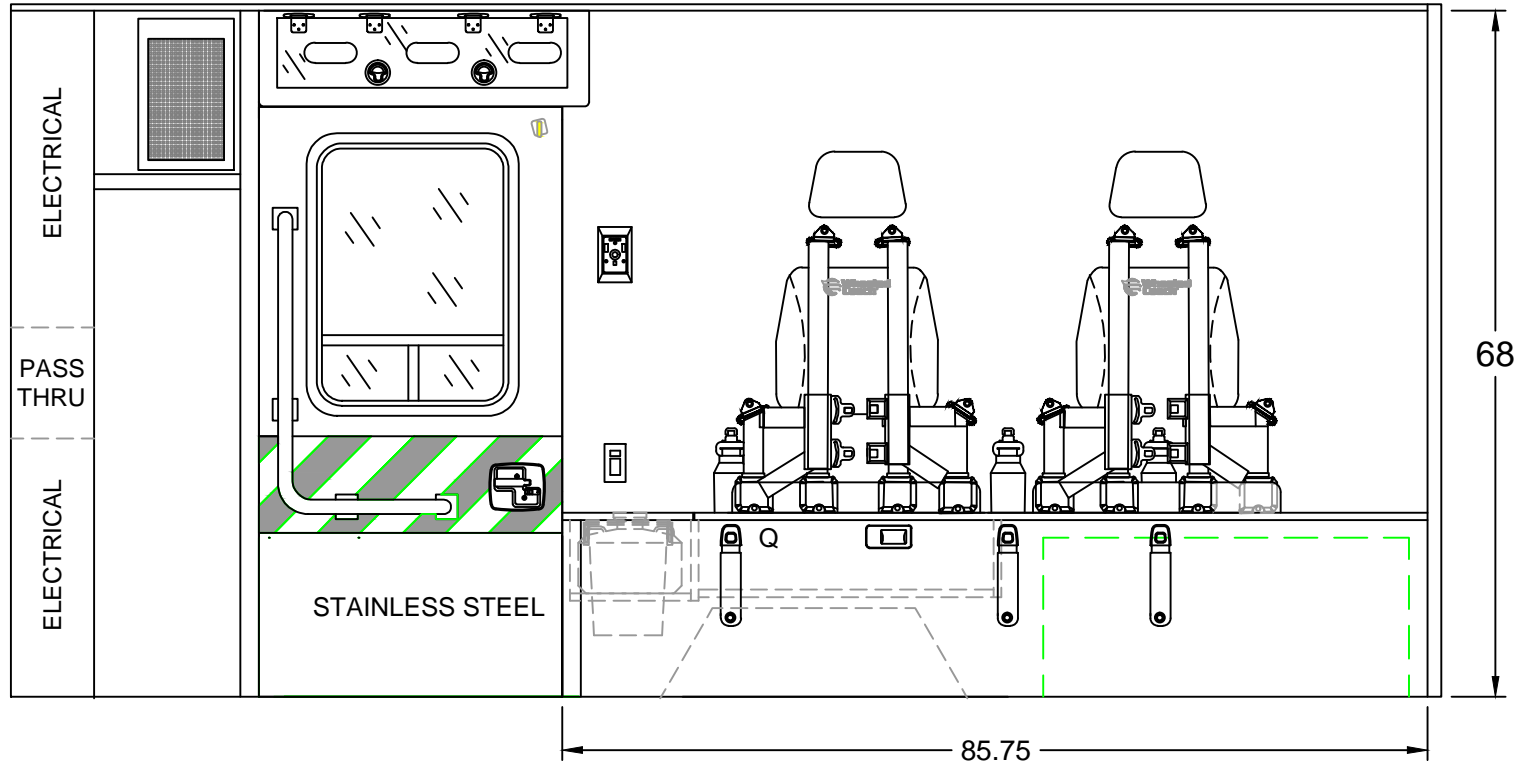

INTERIOR CABINET DIMENSIONS IN INCHES

| COMPT. | HEIGHT | WIDTH | DEPTH | | COMPT. | HEIGHT | WIDTH | DEPTH | |
|--------|--------|-------|-------|--|--------|--------|-------|-------|--|
| Q | 6.75 | 29.25 | 16.00 | | | | | | |
| | | | | | | | | | |
| | | | | | | | | | |
| | | | | | | | | | |

49" AISLE

CABINET WEIGHT RATINGS:
 RESTOCKING = 30 LBS.
 NON-RESTOCKING = 40 LBS.

BE ADVISED THAT THESE ARE PRELIMINARY LAYOUTS INTENDED TO ILLUSTRATE DESIGN INTENT AND DIMENSIONS ARE FOR REFERENCE ONLY PRIOR TO FINAL ENGINEERING



TYPE 1 CHEVY 2018
 RIGHT INTERIOR

DATE: 04/17/18

SCALE

DWN BY

SG

DWG NO

6 / 9

CA111205

MODEL 1146C

146 x 90 x 68

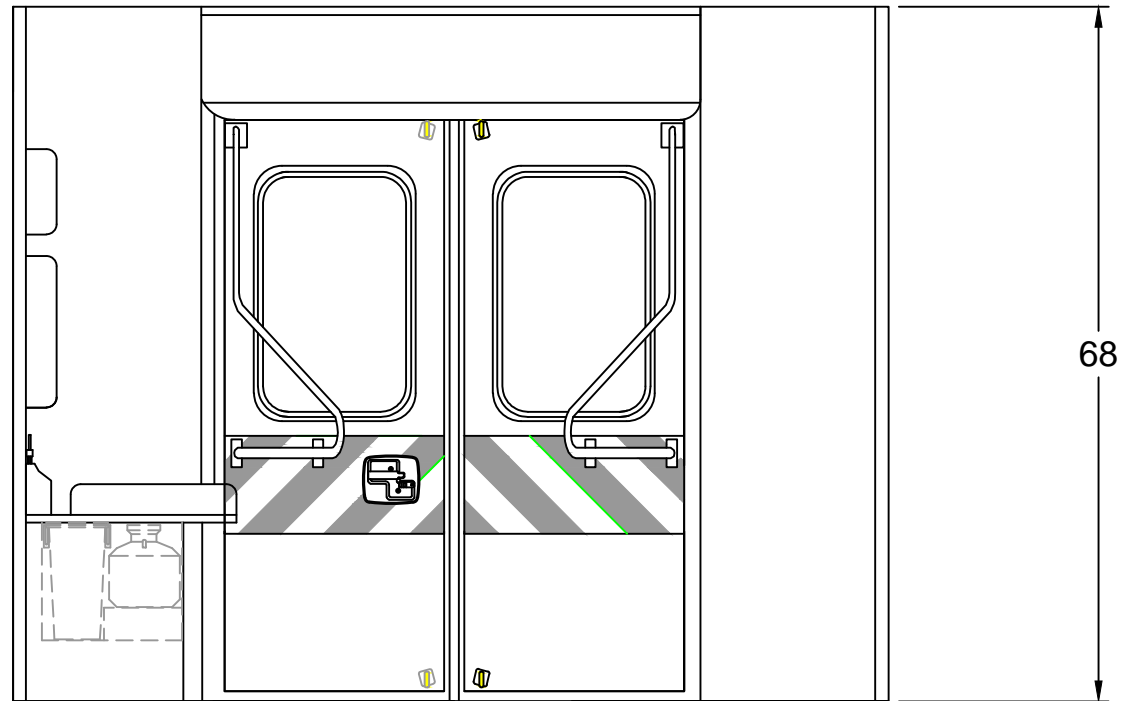

INTERIOR CABINET DIMENSIONS IN INCHES



TYPE 1 CHEVY 2018

REAR BULKHEAD INTERIOR

| | | | |
|-----------|----------|---------|-------|
| DATE: | 04/17/18 | SCALE: | |
| DRAWN BY: | SG | DWG NO: | 7 / 9 |

| COMPT. | HEIGHT | WIDTH | DEPTH | | COMPT. | HEIGHT | WIDTH | DEPTH | |
|--------|--------|-------|-------|--|--------|--------|-------|-------|--|
| | | | | | | | | | |
| | | | | | | | | | |
| | | | | | | | | | |
| | | | | | | | | | |

49" AISLE

CABINET WEIGHT RATINGS:
 RESTOCKING = 30 LBS.
 NON-RESTOCKING = 40 LBS.

BE ADVISED THAT THESE ARE PRELIMINARY LAYOUTS INTENDED TO ILLUSTRATE DESIGN INTENT AND DIMENSIONS ARE FOR REFERENCE ONLY PRIOR TO FINAL ENGINEERING

CA111205

MODEL 1146C

146 x 90 x 68

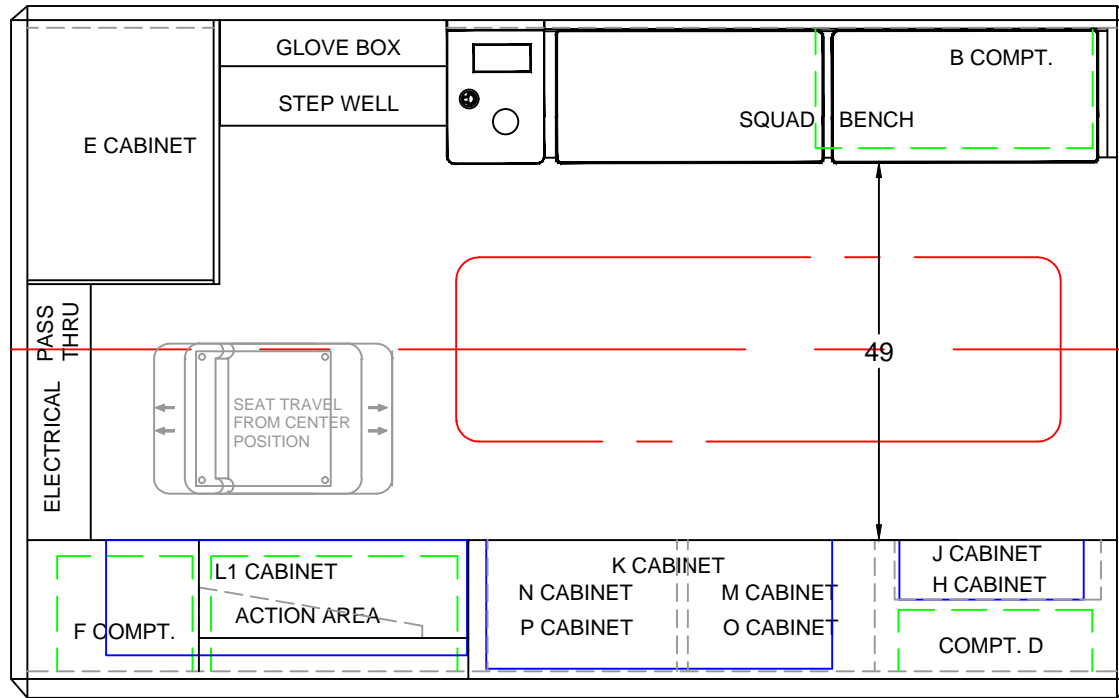

BE ADVISED THAT THESE ARE PRELIMINARY LAYOUTS INTENDED TO ILLUSTRATE DESIGN INTENT AND DIMENSIONS ARE FOR REFERENCE ONLY PRIOR TO FINAL ENGINEERING

| INTERIOR CABINET DIMENSIONS IN INCHES | | | | | | | |  | | |
|---------------------------------------|--------|-------|-------|---------|--------|-------|-------|---|----------|--------|
| CABINET | HEIGHT | WIDTH | DEPTH | CABINET | HEIGHT | WIDTH | DEPTH | | | |
| | | | | | | | | TYPE 1 CHEVY 2018 FLOOR PLAN | | |
| | | | | | | | | | | |
| | | | | | | | | | | |
| | | | | | | | | | | |
| | | | | | | | | | | |
| 49" AISLE | | | | | | | | DATE: | 04/17/18 | SCALE |
| | | | | | | | | DWN BY | SG | DWG NO |

CA111205

MODEL 1146C

146 x 90 x 68

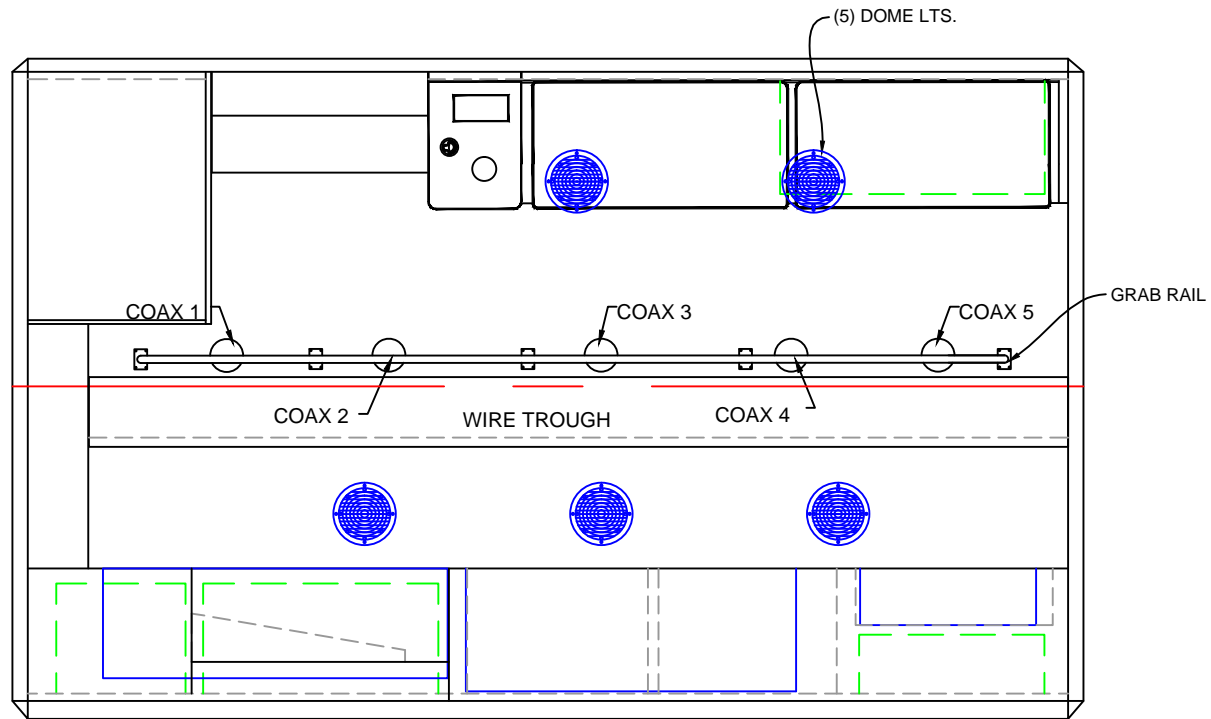

BE ADVISED THAT THESE ARE PRELIMINARY LAYOUTS INTENDED TO ILLUSTRATE DESIGN INTENT AND DIMENSIONS ARE FOR REFERENCE ONLY PRIOR TO FINAL ENGINEERING

INTERIOR CABINET DIMENSIONS IN INCHES

| CABINET | HEIGHT | WIDTH | DEPTH | CABINET | HEIGHT | WIDTH | DEPTH |
|---------|--------|-------|-------|---------|--------|-------|-------|
| | | | | | | | |
| | | | | | | | |
| | | | | | | | |
| | | | | | | | |
| | | | | | | | |



TYPE 1 CHEVY 2018
LINER

DATE: 04/17/18 SCALE:
DWN BY: SG DWG NO: 9 / 9

49" AISLE